

U-MAD[®] TRAILER

NCHRP 350 TL-2 and TL-3 Trailer Truck Mounted Attenuator

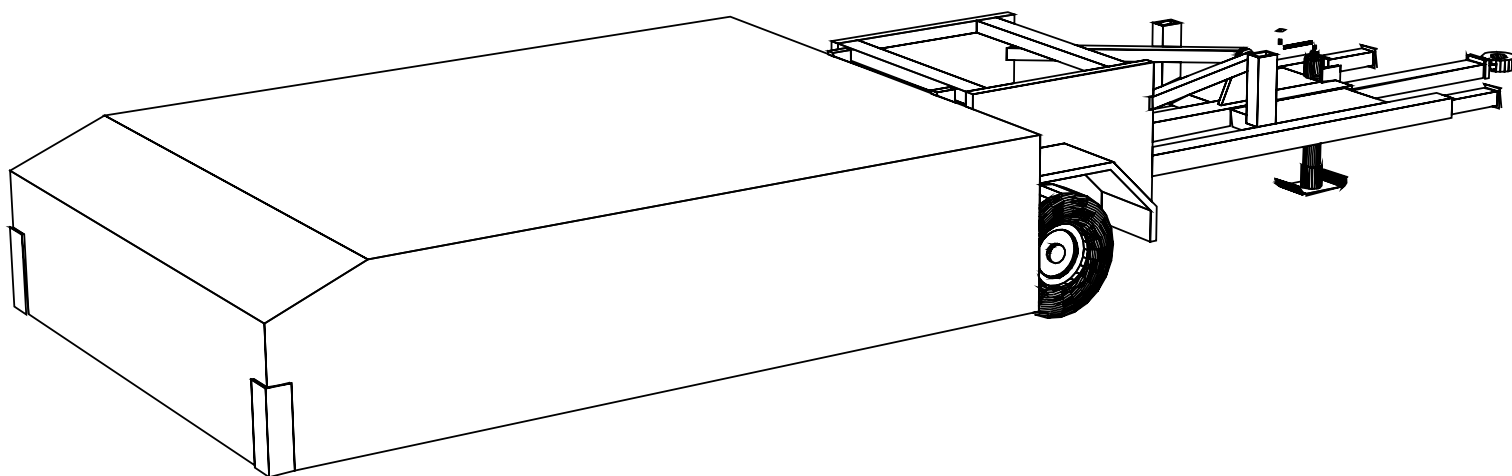

TABLE OF CONTENTS

| | |
|----------------------------|----|
| Preface | 3 |
| Introduction | 3 |
| System Overview | 3 |
| Required Tools | 3 |
| Before Installation | 3 |
| Limitations and Warnings | 4 |
| Limited Warranty | 4 |
| Installation | 4 |
| Safety Statements | 5 |
| Preparing for Installation | 9 |
| System Installation | 9 |
| Maintenance | 13 |

APPENDIX A

| | |
|--|----|
| Roll Ahead Distances for Shadow Vehicles | 15 |
| Wheel Torque Requirements | 17 |
| Wiring Details | 18 |

APPENDIX B: Drawings

| | |
|--|----|
| B080165-US Trailer, U-MAD Trailer TMA | 20 |
| B080188-US U-MAD Trailer Mounted TMA | 21 |
| B081258 U-MAD Trailer TMA Truck Installation Configuration | 22 |

Preface

The Barrier Systems, Inc. (BSI) U-MAD® Trailer Mounted Attenuator incorporates the newest roadside safety materials and engineering processes.

As with any roadside safety device, the U-MAD Trailer Mounted Attenuator must be installed properly to ensure optimum performance. Thoroughly review and fully understand the installation instructions and product limitations before starting the installation. Do not start the installation without the proper plans and tools required.

If you need additional information, or have questions about the U-MAD Trailer Mounted Attenuator, please call the BSI Customer Service Department at (888) 800-3691 (U.S. toll free) or (707) 374-6800.

Introduction

Barrier Systems, the leader in engineering road safety products with low lifecycle costs, has developed a new product that utilizes standard inventory parts and has outstanding reusability. The U-MAD Trailer Mounted Attenuator features a reusable trailer that only requires replacement of a standard U-MAD cartridge after typical design impacts.

System Overview

The U-MAD Trailer Mounted Attenuator has been engineered to capture an errant vehicle during a design impact and keeps both the impacted and impacting vehicles in the same traveling lane. The system meets all mandatory and optional NCHRP 350 TL-3 tests, and it is also available as a TL-2 system. The U-MAD Trailer Mounted Attenuator utilizes the time tested energy absorbing cartridge performance of the U-MAD TMA.

Required Tools

Standard mechanics tools are required to install the U-MAD Trailer Mounted Attenuator. These tools include, but are not limited to:

1. Lifting device (standard fork lift with fork extensions, minimum 8')
2. Tape measure
3. 610 mm + (24" +)level
4. 2 ea. 38 mm (1 ½") combination wrench
5. 2 ea. 16mm (5/8") combination wrench
6. Torque wrench (minimum range 20-235 ft./Lb.)

Note: If welding is required, use only a certified welder.

Remove the parts list from the sealed package and check that all of the parts are present. Report missing parts to your Distributor or Barrier Systems Customer Service within 48 business hours.

Before Installing The U-MAD Trailer Truck Mounted Attenuator

This manual contains important information on the U-MAD Trailer Mounted Attenuator. Proper installation and operation of the U-MAD Trailer is essential to assure maximum performance. Take the time to review this entire manual thoroughly prior to installing and/or operating the U-MAD Trailer.

The U-MAD Trailer Mounted Attenuator is a highly engineered safety device made up of a relatively small number of parts. Before starting the assembly, become familiar with the basic elements that make up the system.

Limitations and Warnings

The U-MAD Trailer Truck Mounted Attenuator has been rigorously tested and evaluated per the recommendations in the NCHRP Report 350 guidelines for terminals and crash cushions. The impact conditions tested in NCHRP 350 are intended to address typical in-service collisions.

When properly installed and maintained, the system is capable of containing and redirecting impacting vehicles in a predictable and safe manner under the NCHRP 350 impact conditions.

Standard Warranty

LIMITED WARRANTY

Lindsay Transportation Solutions, Inc. "LTS" (formerly Barrier Systems) has tested the impact performance of its barriers and crash cushion systems, and other highway safety hardware under controlled conditions, however, LTS does not represent nor warrant that the results of those controlled conditions would necessarily avoid injury to persons or property. LTS EXPRESSLY DISCLAIMS ANY WARRANTY OR LIABILITY FOR CLAIMS ARISING BY REASONS OF DEATH OR PERSONAL INJURY OR DAMAGE TO PROPERTY RESULTING FROM ANY IMPACT, COLLISION OR HARMFUL CONTACT WITH THE PRODUCTS OR NEARBY HAZARDS OR OBJECTS BY ANY VEHICLE, OBJECTS OR PERSONS.

LTS warrants that any product or component part manufactured by LTS will be free from defects in material or workmanship. LTS will replace free of cost any Product or component part manufactured by LTS that contains such a defect.

THE FOREGOING WARRANTY IS IN LIEU OF AND EXCLUDES ALL OTHER WARRANTIES NOT EXPRESSLY SET FORTH HEREIN, WHETHER EXPRESS OR IMPLIED BY OPERATION OF LAW OR OTHERWISE, INCLUDING BUT NOT LIMITED TO ANY IMPLIED WARRANTIES OF MERCHANTABILITY OR FITNESS FOR A PARTICULAR PURPOSE.

LTS' LIABILITY UNDER THIS WARRANTY IS EXPRESSLY LIMITED TO REPLACEMENT FREE OF COST (IN THE FORM AND UNDER THE TERMS ORIGINALLY SHIPPED), OR TO REPAIR OR TO MANUFACTURE BY LTS, PRODUCTS OR PARTS NOT COMPLYING WITH LTS SPECIFICATIONS, OR, AT LTS' ELECTION, TO THE REPAYMENT OF AN AMOUNT EQUAL TO THE PURCHASE PRICE OF SUCH PRODUCTS OR PARTS, WHETHER SUCH CLAIMS ARE FOR BREACH OF WARRANTY OR NEGLIGENCE. LTS SHALL NOT BE LIABLE FOR ANY INCIDENTAL, CONSEQUENTIAL OR SPECIAL LOSSES, DAMAGES OR EXPENSES OF ANY KIND, INCLUDING, WITHOUT LIMITATION, ANY SUCH LOSSES, DAMAGES OR EXPENSES ARISING DIRECTLY OR INDIRECTLY FROM THE SALE, HANDLING OR USE OF THE PRODUCTS FROM ANY OTHER CAUSE RELATING THERETO, OR FROM PERSONAL INJURY OR LOSS OF PROFIT.

Any claim by the Buyer with reference to Products sold hereunder for any cause shall be deemed waived by the Buyer unless LTS is notified in writing, in the case of defects apparent on visual inspection, within ninety (90) days from the delivery date, or, in the case of defects not apparent on visual

inspection, within twelve (12) months from the said delivery date. Products claimed to be defective may be returned prepaid to LTS' plant for inspection in accordance with return shipping instructions that

LTS shall furnish to the Buyer forthwith upon receipt of the Buyer's notice of claim. If the claim is established, LTS will reimburse that Buyer for all carriage costs incurred hereunder.

The forgoing warranty benefits shall not apply to (i) any Products that have been subject to improper storage, accident, misuse or unauthorized alterations, or that have not been installed, operated and maintained in accordance with approved procedures and (ii) any components manufactured by the Buyer.

W030587 Rev. 8 revised February 4, 2013

System Installation: General Safety

The U-MAD Trailer Mounted Attenuator is designed to reduce the risk of injury to the driver of the work vehicle, to the driver of an errant vehicle, and to assist in reduce risk of damage to the work equipment. The U-MAD Trailer Mounted Attenuator attaches to the rear of the support vehicle and may be used in stationary applications such as protecting workers in a work zone, as well as in mobile operations, such as striping, sweeping, plowing, etc.

The U-MAD Trailer Mounted Attenuator consists of the following basic components: a crushable cartridge, trailer body, pintle attachment and stabilizer assembly, suspension, wheels, and tires (see Figures 1 and 2).

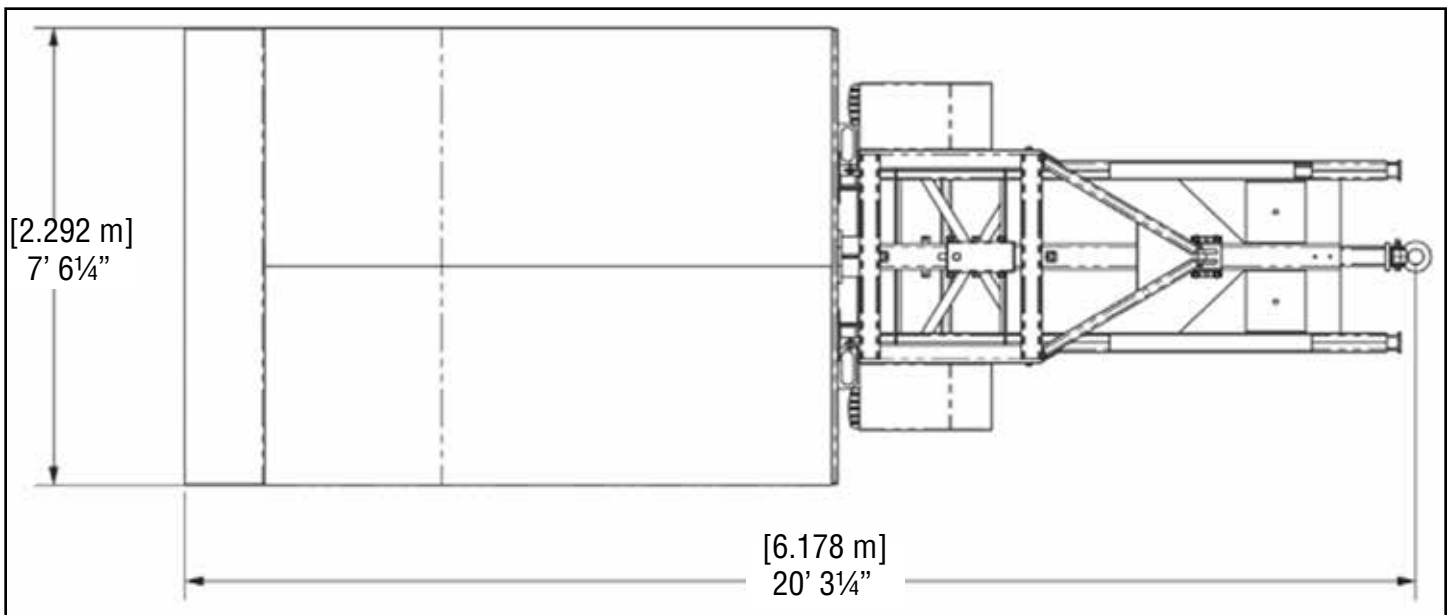

Figure 1. U-MAD Trailer Overhead View

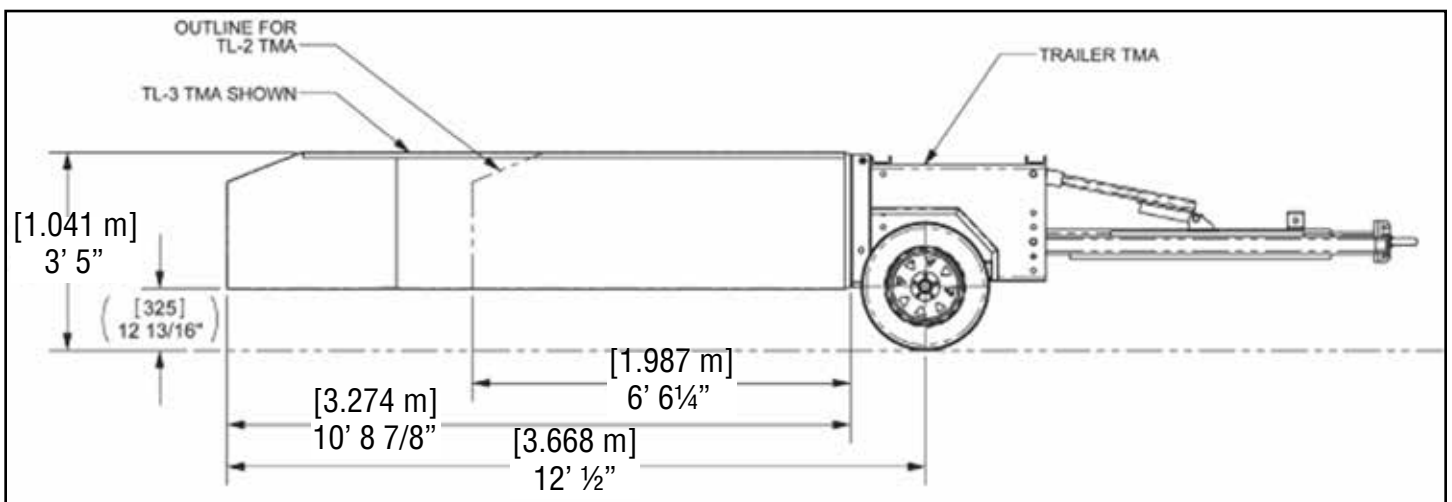

Figure 2. U-MAD Trailer Side View

1. The U-MAD Trailer should be securely fastened to the support vehicle by proper attachment of the pintle and receiver ring, along with the security chains to the towing support vehicle (see Figures 3 and 4).



Figure 3. Pintle hook receiver ring



Figure 4. Security chains

2. The Trailer requires the use of a pintle hook with a rating of 6 tons or greater.

3. The U-MAD Trailer cartridge is crucial to system performance. **DO NOT** place any heavy objects on the cartridge that may cause damage (see Figure 6, page 7).

4. Proper height of the cartridge must be followed. On level ground the measurement of the cartridge needs to be 305mm +/- 25.4mm (12 inches +/- 1 inch, see Figure 5).



Figure 5. Measuring for cartridge height

5. The U-MAD Trailer can be used with a range of support vehicles. The preferred support weight is approximately 19,065lbs. If ballast is to be used it **MUST BE ADEQUATELY ANCHORED** to the truck to prevent shifting during an impact. (Please see Appendix A: "Roll Ahead Distances for Shadow Vehicles")

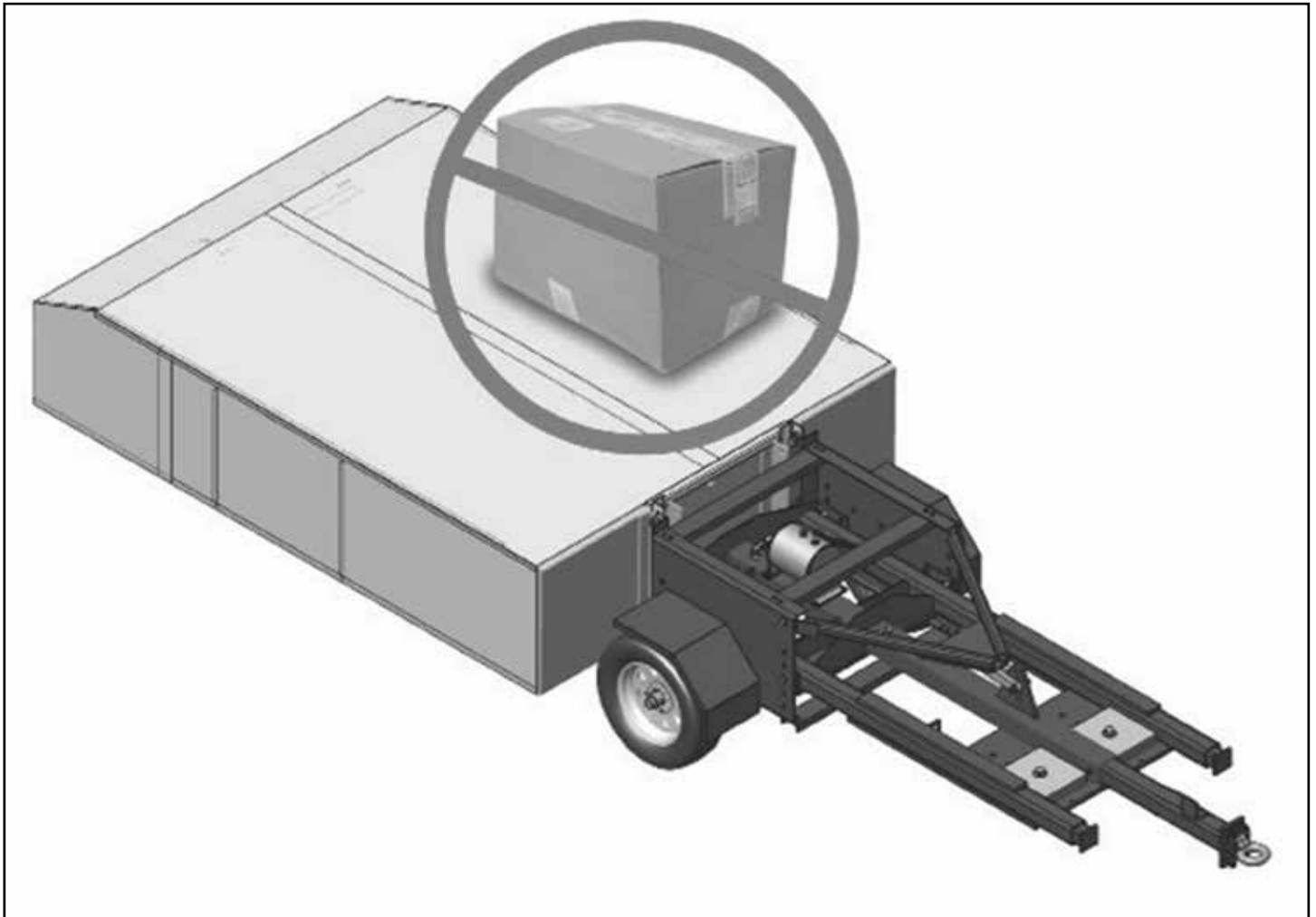

Figure 6. Do not place heavy objects on the U-MAD Trailer cartridge

6. Ensure that the U-MAD Trailer is in good working order with no damage, corrosion, or other maintenance issue hindering its designed operation. This should be a part of a routine visual inspection before each use.

Warning: Failure to comply with the following instructions can result in improper U-MAD Trailer TMA performance and possible injury.

7. Regular maintenance should include, but not be limited to, the following items:
- A. Do not modify or change the trailer in any way. Never weld, bolt or modify anything to the trailer.
 - B. The U-MAD Trailer must go through routine inspections and should be visually inspected prior to each use.

- C. Use a correctly rated pintle hook (6 tons or greater, see Figure 8).



Figure 8. Use a correctly rated pintle hook

- D. Periodically check and maintain the correct tire pressure. Inflate trailer tires to the maximum inflation indicated on the tire side wall (see Figure 9).



Figure 9. Check and maintain proper tire pressure

- E. When replacing trailer tires, wheels and tires must be matched.
- F. Make sure the wheel lug nuts are tightened to the correct torque. It is necessary to re-torque the lug nuts several times until the lug nut torque stabilizes. (Please see Appendix A: "Wheel Torque Requirements")

- G. Always use safety chains when towing. Cross the safety chains under coupling to prevent the tongue from dropping to ground in case of connection failure. Allow only enough slack for tight turns.

- H. Do not let the safety chains drag on the ground. Twist the safety chains equally from the hook ends to take up slack.

- I. Ensure that the wiring is properly connected and not touching the road, but loose enough to make turns without disconnecting or damaging the wires (see Figure 10).

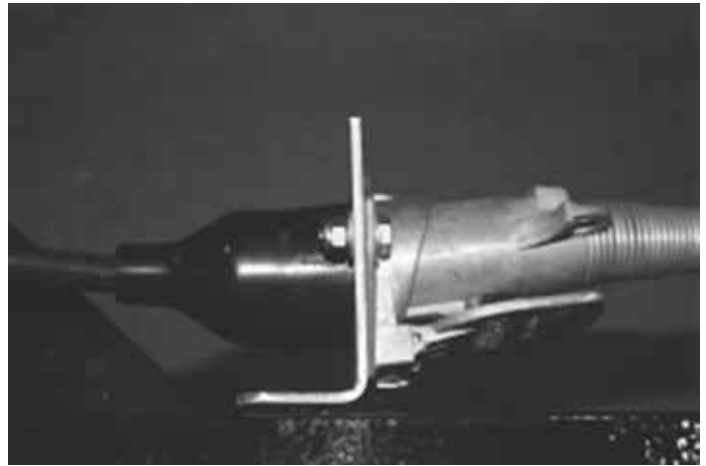

Figure 10. Ensure wiring is properly connected

- J. Always do a pre-trip walk around, visually checking on the trailer, the pintle, hoses, tires, chains, wiring, lights operating properly, fittings, and your support vehicle. Fix any deficiencies before operating.

If you need additional information, or have questions about the U-MAD Trailer Mounted Attenuator, please call the BSI Customer Service Department at (888) 800-3691 (U.S. toll free) or (707) 374-6800.

System Installation: Preparing for Installation

Read and understand all instructions before beginning installation of the U-MAD Trailer Mounted Attenuator. Review drawings in the manual to further familiarize yourself with the system.

The U-MAD Trailer was tested to the NCHRP 350 criteria attached to a support vehicle weighing 8,550 kg (18,850 lb.) to 9450 kg (20,830 lb.). To obtain NCHRP 350 performance, a similar vehicle should be used. The U-MAD Trailer will be attached to the support vehicle by way of a minimum 6-ton pintle hitch. A crucial part of the system during an impact is the engagement of the stabilizer arms to the body of the truck. Please ensure that the truck has proper underride to engage the stabilizer arms.

System Installation

Secure a safe, level work site where you can carefully remove the protective shipping material from the unit.

Carefully remove the protective shipping material from the U-MAD Cartridge.

The support vehicle should be as close to the final driving weight as possible. If ballast is needed, add it at this time. Ballast must be properly anchored to the support vehicle to keep it in place during an impact. Ideally, an adequately sized support vehicle that requires no ballast should be used. Because the tongue weight of the U-MAD Trailer is supported by the back of the shadow vehicle, be sure not to exceed the manufacturer's published maximum axle loads.

Make sure that nothing is impeding the connection and function of the trailer. Impediments with the frame, springs, attachments, tail lights, etc. should be corrected before proceeding.

Ensure that the trailer is level by adjusting the jack stand. Block the tires so the trailer will not move. With the fork lift and extensions carefully placed under the cartridge (so as to not cause damage), lift the cartridge from the back and align the holes of the C-channel with the angle iron on the trailer (See Figure 12).



Figure 12. Insert (2) 7/8" (22 mm) x 2 1/2" (64 mm) bolts on each side of the cartridge to attach

Once the cartridge is mounted onto the trailer, verify that the cartridge is level, and measure the distance from the bottom of the cartridge to the ground. This measurement will be 305 mm +/- 25.4 mm (12" +/- 1"). If for any reason this measurement is off, use the leveler bolts to adjust the height of the cartridge. Raise cushion, loosen jam nut on bolts at the bottom of the lift (See Figure 13).

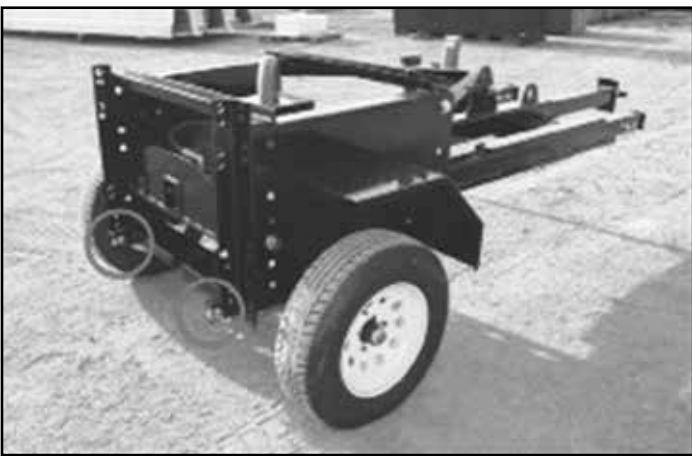

Figure 13. Loosen the jam nuts

Tighten 1/4 turn to lower the rear of cushion 25.4 mm (1"). Reverse the process to raise the rear of the cartridge. Once the proper height has been obtained, tighten the jam nuts and recheck.

The trailer is now ready to be connected to the support vehicle.

Attach U-MAD Trailer

Most trucks have a full underride frame or a 12.7 mm (1/2") stabilizer plate welded across the back frame members and a pintle hook. If this is not present on your truck, start by making sure the frame is square by measuring back from the spring shackles. Modify the frame if needed. Once the frame is squared, the plate can be welded or bolted on. BSI does offer a stabilizer kit that can be quickly and easily attached to most support vehicles.

Welding

Always observe federal, state, local, and auto manufacturer's requirements for welding. Have your welder start by reviewing this manual and checking the vehicle. The welder should grind the frame ends to prepare for the mounting of the stabilizer plate. You can use the BSI stabilizer plate kit or a piece of 12.7 mm (1/2") steel plating 1.07 m x 25.4 mm (42" x 12"). Grind the plating where it will be joined to the frame. Clamp the plate into position and tack into place (see Figure 14).

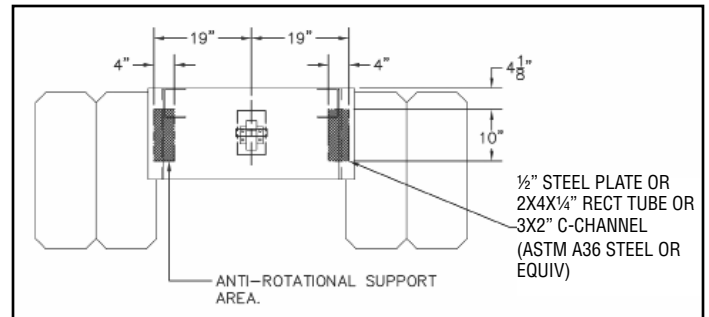

Figure 14. Truck stabilizer plate

Verify that the plate is correctly centered over the frame. Complete the welding of the plate. Trucks with small or modified frames may require additional support. Please contact Customer Service for further evaluation.

Bolt On

Have a local fabricator familiar with all relevant laws and guidelines complete this modification to the support vehicle. The fabricator should start by cutting two 101 mm x 101 mm x 12.7 mm (4" x 4" x ½") angle iron pieces the height of the C-channel. Measure and mark four 22.2 mm (7/8") holes. The spacing needs to be of equal distance both vertically and horizontally. Make sure the holes are spaced at least 50.8 mm (2") apart. Double check the measurements and drill the holes. Mark the frame of the support vehicle by using the angle iron as a template and drill the 22.2 mm (7/8") holes in the frame. Bolt the angle iron into place using two 19 mm (¾") grade 8, zinc coated, hex head bolts on each side. Use either the BSI stabilizer plate kit or a 12.7 mm (½") steel plate that is 1.07 m x 25.4 mm (42" x 12"). Align with the frame and drill matching holes in the plate. Mount the plate using four 19 mm (¾") grade 8, zinc coated, hex head bolts. If the plate hangs below the frame, use 76.2 mm (3") angle iron to add additional support from the frame (see Figure 15).

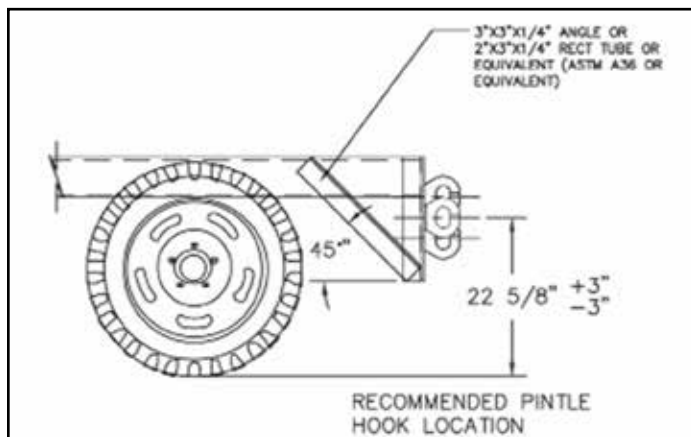

Figure 15. Use angle iron for additional support

Attach the receiver ring of the trailer to the pintle hook of the support vehicle. Ensure that the trailer is level and the cartridge is still 305 mm +/- 25 mm (12" +/- 1") off the ground. If the trailer is not level, adjust the receiver ring with 2ea 15.9 mm (5/8") combination wrenches (see Figure 16).

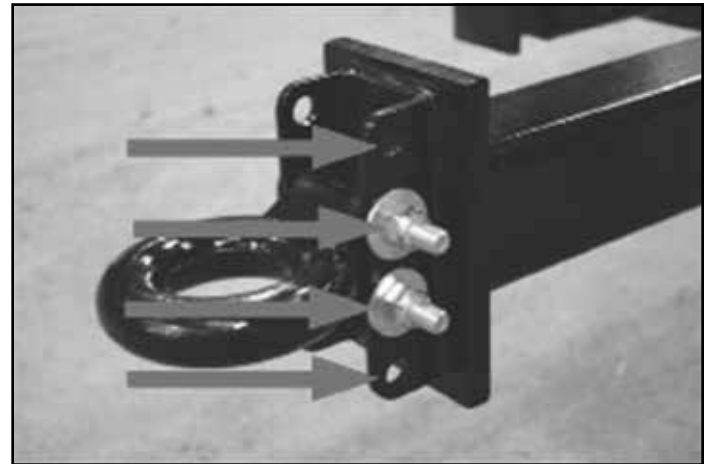

Figure 16. Adjust the receiver ring

Once the trailer is level and the adjustments have been made, verify the cartridge is within tolerance as stated above. Locate the 7-pin connector on the cartridge and connect it to your support vehicle (see Figure 17).



Figure 17. The 7-pin connector



Figure 18. Safety chains

Check lights to ensure that each is operating properly. Make sure the cable does not drag on the ground. (Please see Appendix A: "Wiring Details")

Attach the safety chains to the support vehicle. Make sure that the chains are crossed and not dragging the ground (see Figure 18).

At this time you can place the jack in the stored position. Visually check that the pin is engaged to keep the jack from slipping and dragging the ground (see Figure 19).



Figure 19. The jack pin is engaged

Final Check

A final check of the system should include checking the tightness of all fasteners and the height and levelness of the unit. You are ready to use the U-MAD Trailer Mounted Attenuator. All U-MAD Trailer operators must be given this manual in conjunction with operating and safety training as specified by the owner and local authorities/regulations.

Checking the tightness of all fasteners



Maintenance

This manual contains important information on maintenance of the U-MAD Trailer Mounted Attenuator. Proper maintenance is essential to assure maximum performance. Take the time to review this entire manual thoroughly prior to installing, operating, and maintaining the U-MAD Trailer. If you need additional information or have questions about the U-MAD Trailer, please call your local Distributor or the Barrier Systems Customer Service Department at (888) 800-3691 (U.S. Toll Free) or 1-707-374-6800, or write to: Lindsay Transportation Solutions Sales and Services, Inc 180 River Road • Rio Vista, CA 94571, or email to info@barriersystemsinc.com.

The U-MAD Trailer Mounted Attenuator is a highly engineered safety device made up of a relatively small amount of parts. Before conducting maintenance on the unit, become familiar with the basic elements that make up the system. The U-MAD Trailer requires a visual inspection before each deployment. For routine maintenance:

1. Check that the tire pressure and lug nut torque are within manufacturer's specifications see Figure 20).



Figure 20. Check tire pressure and lug torque

2. Check the hydraulic fluid level. Add hydraulic fluid if required. **DO NOT OVERFILL**. Check hoses and fittings for wear (see Figure 21).



Figure 21. Check hydraulic fluid

3. Check torque on all mounting nuts (235 ft./lb., see Figure 22).



Figure 22. Check torque on mounting nuts

4. Inspect for damage or irregularities. Refer to the U-MAD Cartridge Repair Guide for cartridge damage issues (Barrier Systems Marketing Materials Part Number UM06, see Figure 23).

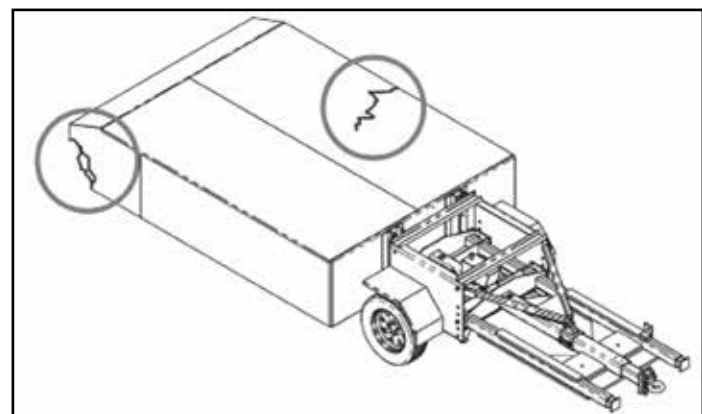

Figure 23. Inspect for damage or irregularities

5. Check all electrical fittings and pigtails (see Figure 24). Check taillights for mounting, damage, and functionality. Please see Appendix A: "Wiring Details"

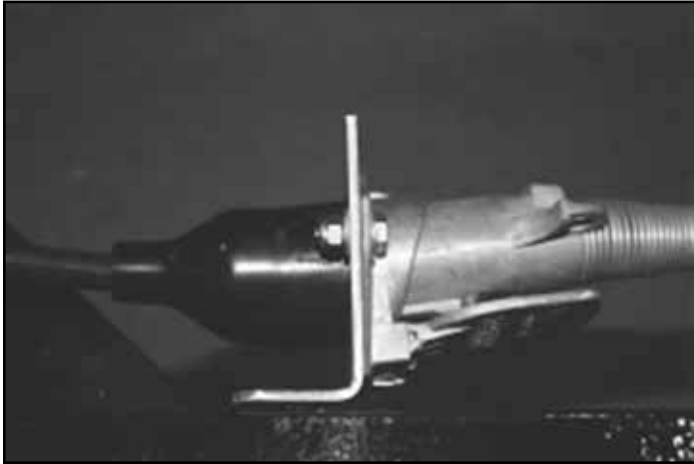

Figure 24. Check electrical fittings

6. Ensure a correctly rated pintle hook (minimum 6-ton capacity) is mounted on the support vehicle (see Figure 25).



Figure 25. Check for correctly rated pintle hook

7. Verify that safety chains are securely attached to the trailer and support vehicle, and that safety chains are not dragging on the ground and there is no wear on the chains (see Figure 26).



Figure 26. Safety chains

8. Always do a pre-trip walk-around inspection checking the above items. Consider your local conditions and regulations when performing your pre-trip inspection and maintenance, and modify accordingly.

If you need additional information, or have questions about the U-MAD Trailer Mounted Attenuator, please call your local distributor or the BSI Customer Service Department at (888) 800-3691 (U.S. toll free) or (707) 374-6800.

Appendix A

Roll Ahead Distances: Shadow Vehicles

Roll-Ahead Distances for Shadow Vehicles - U.S. Units

| Weight of Shadow Vehicle (moving) | Prevailing speed (mph) | Weight of Impacting Vehicle to be Contained* | | | |
|-----------------------------------|------------------------|--|------------|------------|------------|
| | | 4,500 lbs | 10,000 lbs | 15,000 lbs | 24,000 lbs |
| 10,000 lbs | 60-65 | 100 ft | 175 ft | 225 ft | 275 ft |
| | 50-55 | 100 ft | 150 ft | 175 ft | 200 ft |
| | 45 | 75 ft | 100 ft | 125 ft | 150 ft |
| 15,000 lbs | 60-65 | 75 ft | 150 ft | 175 ft | 225 ft |
| | 50-55 | 75 ft | 125 ft | 150 ft | 175 ft |
| | 45 | 50 ft | 100 ft | 100 ft | 100 ft |
| 24,000 lbs | 60-65 | 75 ft | 100 ft | 150 ft | 175 ft |
| | 50-55 | 50 ft | 75 ft | 100 ft | 150 ft |
| | 45 | 50 ft | 75 ft | 75 ft | 100 ft |

Note: Distances are appropriate for shadow vehicles speeds up to 15 mph.

***Weights of typical vehicles:**

- Mid-size automobile — 2,250 lbs
- Full-size automobile — 3,500 lbs
- Loaded 3/4-ton pickup truck — 6,000 lbs
- Loaded 1-ton cargo truck — 10,000 lbs
- Loaded 4-yard dump truck — 24,000 lbs

Source Note: Humphrey/Sullivan Report

Appendix A

Roll Ahead Distances: Barrier Vehicles

Roll-Ahead Distances for Barrier Vehicles - U.S. Units

| Weight of Barrier Vehicle (stationery) | Prevailing speed (mph) | Weight of Impacting Vehicle to be Contained* | | | |
|--|------------------------|--|------------|------------|------------|
| | | 4,500 lbs | 10,000 lbs | 15,000 lbs | 24,000 lbs |
| 10,000 lbs | 60-65 | 50 ft | 100 ft | 150 ft | 200 ft |
| | 50-55 | 25 ft | 75 ft | 100 ft | 150 ft |
| | 45 | 25 ft | 50 ft | 75 ft | 100 ft |
| 15,000 lbs | 60-65 | 25 ft | 75 ft | 100 ft | 150 ft |
| | 50-55 | 25 ft | 50 ft | 75 ft | 100 ft |
| | 45 | 25 ft | 25 ft | 50 ft | 75 ft |
| 24,000 lbs | 60-65 | 25 ft | 50 ft | 75 ft | 100 ft |
| | 50-55 | 25 ft | 25 ft | 50 ft | 75 ft |
| | 45 | 25 ft | 25 ft | 25 ft | 50 ft |

***Weights of typical vehicles:**

- Mid-size automobile — 2,250 lbs
- Full-size automobile — 3,500 lbs
- Loaded 3/4-ton pickup truck — 6,000 lbs
- Loaded 1-ton cargo truck — 10,000 lbs
- Loaded 4-yard dump truck — 24,000 lbs

Source Note: Humphrey/Sullivan Report

Appendix A

Wheel Torque Requirements

It is extremely important to apply and maintain proper wheel mounting torque on your trailer axle. Torque is a measure of the amount of tightening applied to a fastener (nut or bolt) and is expressed as length times force. For example, a force of 90 pounds applied at the end of wrench one foot long will yield 90 lbs.-ft. of torque. Torque wrenches are the best method to assure the proper amount of torque is being applied to a fastener.

Note: Wheel nut or bolts must be applied and maintained at the proper torque levels to prevent loose wheels, broken studs, and possible dangerous separation of wheels from your axle.

Be sure to use only the fasteners matched to the cone angle of your wheel (usually 60 or 90 degrees.) The proper procedure for attaching your wheels is as follows:

1. Start all bolts or nuts by hand to prevent cross threading.
2. Tighten bolts or nuts in the following sequence.

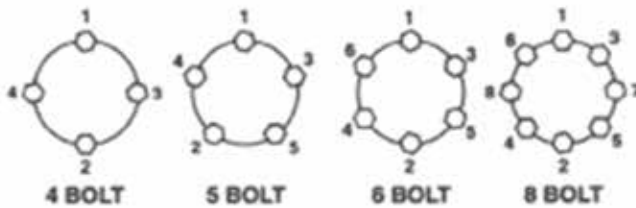

3. The tightening of the fasteners should be done in stages. Following the recommended sequence, tighten fasteners per wheel torque chart below.

4. Wheel nuts/bolts should be torqued before first road use and after each wheel removal. Check and re torque after the first 10 miles, 25 miles, and again at 50 miles. Check periodically thereafter.

Wheel Torque Requirements

| Wheel Size | 1st Stage | 2nd Stage | 3rd Stage |
|--|-------------------------|-----------|-----------|
| 12" | 20 - 25 | 35 - 40 | 50 - 60 |
| 13" | 20 - 25 | 35 - 40 | 50 - 60 |
| 14" | 20 - 25 | 50 - 60 | 90 - 120 |
| 15" | 20 - 25 | 50 - 60 | 90 - 120 |
| 16" | 20 - 25 | 50 - 60 | 90 - 120 |
| 16.5" x 6.75" | 20 - 25 | 50 - 60 | 90 - 120 |
| 16.5" x 9.75" | 55 - 60 | 120 - 125 | 175 - 225 |
| 14.5" Demount | Tighten sequentially to | | 85 - 95 |
| 17.5" Hub Pilot Clamp Ring & Cone Nuts | 50 - 60 | 100 - 120 | 190 - 220 |
| 17.5" Hub Pilot 5/8" Flange Nuts | 50 - 60 | 90 - 200 | 275 - 325 |

Appendix A

Wiring Details

WIRING INSTRUCTIONS FOR 7-PIN ROUND PLUG (1)

1. REMOVE PLASTIC PLUG FROM STEEL CASING.
2. ROUTE 6 WIRE HARNESS THROUGH BACKSIDE OF STEEL CASING.
3. REMOVE APPROX. 4" OF OUTER JACKET
4. WIRE PER DIAGRAM/NOTES BELOW:
5. SECURE PLASTIC PLUG BACK INTO STEEL CASING.
6. TEST COMPLETED LIGHT SYSTEM TO VERIFY PROPER CONNECTIONS.

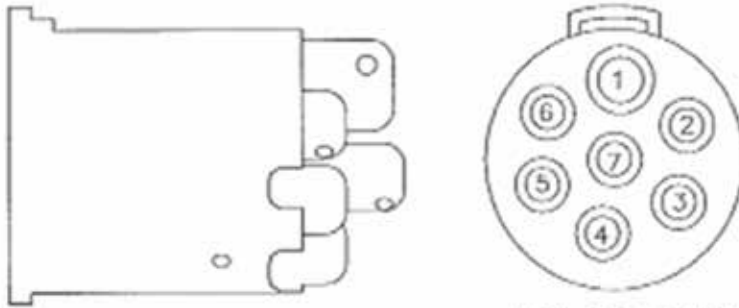

VIEW FOR WIRING

NOTES:

-ON WIRES THAT ARE USED, STRIP APPROX. 1/2" OF WIRE. FOLD BARE WIRE IN HALF (WIRE IS DOUBLE THICKNESS). INSERT WIRE INTO APPROPRIATE PLUG AND TIGHTEN SET SCREW. MAKE SURE SET SCREW IS PUSHING AGAINST BARE WIRE, NOT INSULATION.

-IF A WIRE IS NOT USED, DO NOT STRIP. TUCK THESE WIRES BACK INTO THE HARNESS.

DIAGRAM FOR "OVAL" LIGHT SYSTEM 14-2199-0

| PLUG # | WIRE HARNESS |
|----------|--------------|
| 1 | WHITE |
| 2 | BLACK |
| 3 | GREEN |
| 5 | ORANGE |
| NOT USED | RED |
| NOT USED | BLUE |

DIAGRAM FOR "LED" LIGHT SYSTEM 14-2200-0

| PLUG # | WIRE HARNESS |
|----------|--------------|
| 1 | WHITE |
| 2 | BLACK |
| 3 | GREEN |
| 5 | ORANGE |
| 7 | RED |
| NOT USED | BLUE |

DIAGRAM FOR "24V" LIGHT SYSTEM 14-2202-0

| PLUG # | WIRE HARNESS |
|----------|--------------|
| 1 | WHITE |
| 2 | BLACK |
| 3 | GREEN |
| 5 | ORANGE |
| NOT USED | RED |

Appendix A

Wiring Details (Continued)

| PLUG # | FUNCTION |
|--------|--|
| 1 | GROUND |
| 2 | RUNNING LIGHTS BOTH SIDES |
| 3 | PASS. SIDE ONLY-BRAKE & TURN SHOULD BE BRIGHTER THAN RUNNING LIGHTS |
| 4 | OPEN |
| 5 | DRIVER SIDE ONLY-BRAKE & TURN SHOULD BE BRIGHTER THAN RUNNING LIGHTS |
| 6 | OPEN |
| 7 | 14-2199-0 & 14-2202-0 --OPEN 14-2200-0 -- BACKUP LIGHTS -- WHITE LIGHTS ON LED SYSTEM |

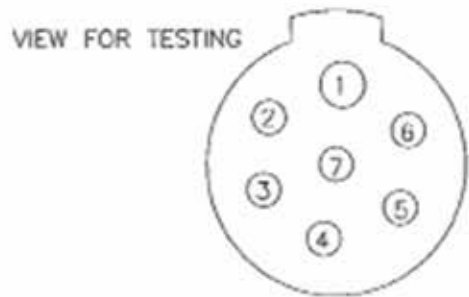

Appendix B

| Part No. | Description | Quantity | Part Code |
|----------|------------------|----------|-----------|
| 1009317 | TMA TRAILER BODY | 1 | EA |
| 1009318 | TMA TRAILER BODY | 1 | EA |
| 1009319 | TMA TRAILER BODY | 1 | EA |
| 1009320 | TMA TRAILER BODY | 1 | EA |
| 1009321 | TMA TRAILER BODY | 1 | EA |
| 1009322 | TMA TRAILER BODY | 1 | EA |
| 1009323 | TMA TRAILER BODY | 1 | EA |
| 1009324 | TMA TRAILER BODY | 1 | EA |
| 1009325 | TMA TRAILER BODY | 1 | EA |
| 1009326 | TMA TRAILER BODY | 1 | EA |
| 1009327 | TMA TRAILER BODY | 1 | EA |
| 1009328 | TMA TRAILER BODY | 1 | EA |
| 1009329 | TMA TRAILER BODY | 1 | EA |
| 1009330 | TMA TRAILER BODY | 1 | EA |
| 1009331 | TMA TRAILER BODY | 1 | EA |
| 1009332 | TMA TRAILER BODY | 1 | EA |
| 1009333 | TMA TRAILER BODY | 1 | EA |
| 1009334 | TMA TRAILER BODY | 1 | EA |
| 1009335 | TMA TRAILER BODY | 1 | EA |
| 1009336 | TMA TRAILER BODY | 1 | EA |
| 1009337 | TMA TRAILER BODY | 1 | EA |
| 1009338 | TMA TRAILER BODY | 1 | EA |
| 1009339 | TMA TRAILER BODY | 1 | EA |
| 1009340 | TMA TRAILER BODY | 1 | EA |
| 1009341 | TMA TRAILER BODY | 1 | EA |
| 1009342 | TMA TRAILER BODY | 1 | EA |
| 1009343 | TMA TRAILER BODY | 1 | EA |
| 1009344 | TMA TRAILER BODY | 1 | EA |
| 1009345 | TMA TRAILER BODY | 1 | EA |
| 1009346 | TMA TRAILER BODY | 1 | EA |
| 1009347 | TMA TRAILER BODY | 1 | EA |
| 1009348 | TMA TRAILER BODY | 1 | EA |
| 1009349 | TMA TRAILER BODY | 1 | EA |
| 1009350 | TMA TRAILER BODY | 1 | EA |
| 1009351 | TMA TRAILER BODY | 1 | EA |
| 1009352 | TMA TRAILER BODY | 1 | EA |
| 1009353 | TMA TRAILER BODY | 1 | EA |
| 1009354 | TMA TRAILER BODY | 1 | EA |
| 1009355 | TMA TRAILER BODY | 1 | EA |
| 1009356 | TMA TRAILER BODY | 1 | EA |
| 1009357 | TMA TRAILER BODY | 1 | EA |
| 1009358 | TMA TRAILER BODY | 1 | EA |
| 1009359 | TMA TRAILER BODY | 1 | EA |
| 1009360 | TMA TRAILER BODY | 1 | EA |
| 1009361 | TMA TRAILER BODY | 1 | EA |
| 1009362 | TMA TRAILER BODY | 1 | EA |
| 1009363 | TMA TRAILER BODY | 1 | EA |
| 1009364 | TMA TRAILER BODY | 1 | EA |
| 1009365 | TMA TRAILER BODY | 1 | EA |
| 1009366 | TMA TRAILER BODY | 1 | EA |
| 1009367 | TMA TRAILER BODY | 1 | EA |
| 1009368 | TMA TRAILER BODY | 1 | EA |
| 1009369 | TMA TRAILER BODY | 1 | EA |
| 1009370 | TMA TRAILER BODY | 1 | EA |
| 1009371 | TMA TRAILER BODY | 1 | EA |
| 1009372 | TMA TRAILER BODY | 1 | EA |
| 1009373 | TMA TRAILER BODY | 1 | EA |
| 1009374 | TMA TRAILER BODY | 1 | EA |
| 1009375 | TMA TRAILER BODY | 1 | EA |
| 1009376 | TMA TRAILER BODY | 1 | EA |
| 1009377 | TMA TRAILER BODY | 1 | EA |
| 1009378 | TMA TRAILER BODY | 1 | EA |
| 1009379 | TMA TRAILER BODY | 1 | EA |
| 1009380 | TMA TRAILER BODY | 1 | EA |
| 1009381 | TMA TRAILER BODY | 1 | EA |
| 1009382 | TMA TRAILER BODY | 1 | EA |
| 1009383 | TMA TRAILER BODY | 1 | EA |
| 1009384 | TMA TRAILER BODY | 1 | EA |
| 1009385 | TMA TRAILER BODY | 1 | EA |
| 1009386 | TMA TRAILER BODY | 1 | EA |
| 1009387 | TMA TRAILER BODY | 1 | EA |
| 1009388 | TMA TRAILER BODY | 1 | EA |
| 1009389 | TMA TRAILER BODY | 1 | EA |
| 1009390 | TMA TRAILER BODY | 1 | EA |
| 1009391 | TMA TRAILER BODY | 1 | EA |
| 1009392 | TMA TRAILER BODY | 1 | EA |
| 1009393 | TMA TRAILER BODY | 1 | EA |
| 1009394 | TMA TRAILER BODY | 1 | EA |
| 1009395 | TMA TRAILER BODY | 1 | EA |
| 1009396 | TMA TRAILER BODY | 1 | EA |
| 1009397 | TMA TRAILER BODY | 1 | EA |
| 1009398 | TMA TRAILER BODY | 1 | EA |
| 1009399 | TMA TRAILER BODY | 1 | EA |
| 1009400 | TMA TRAILER BODY | 1 | EA |

SCALE: 1:25

DATE: 4/27/09

DRAWN BY: INT

APPROVED BY: DF

TITLE: TRAILER, U-MAD TRAILER MOUNTED CRASH CUSHION

Standard Release

Original: 1:07

Revised: 2:11F

Doc XXX: 2:01G

Doc XXX: 2:000

Doc XXX: 2:000

| REV. | CHANGES | DATE | BY | REQD | NEXT ASSY. | ITEM |
|--------|--------------|--------|----|------|------------|------|
| A | SEE ECN 1347 | 5/7/09 | DF | | | |
| 1 OF 1 | B090406 | | | | | |

© 2008 Barrier Systems Inc. The information here on is proprietary to Barrier Systems Inc. and not to be disclosed, copied, or reproduced without the express written approval of Barrier Systems Inc.

Appendix B

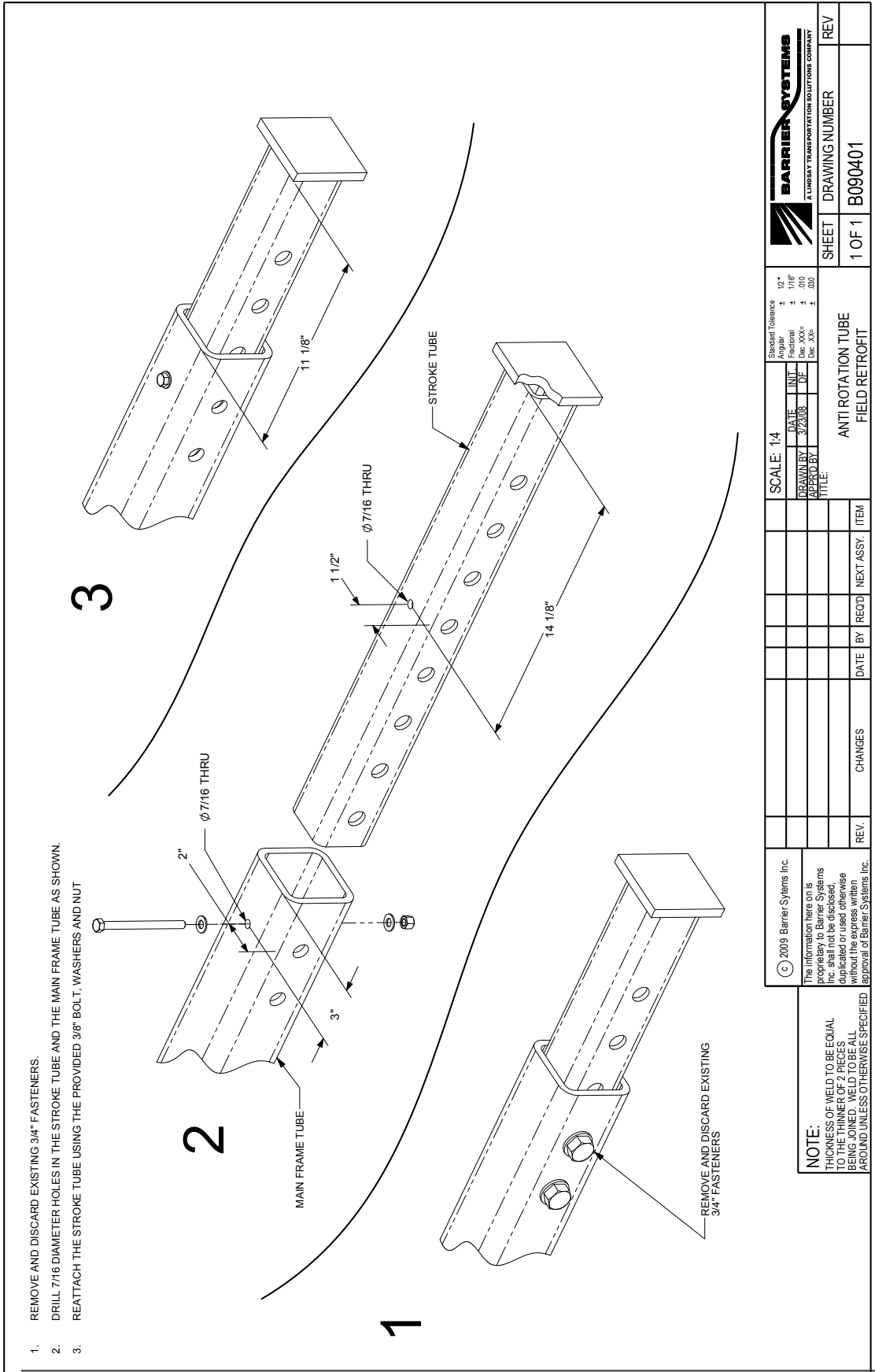

Appendix B

- NOTES:**
1. VEHICLES CONFIGURED FOR USE WITH THE U-MAD TRAILER MOUNTED CRASH CUSHION SHALL HAVE A PINTLE HITCH ATTACHMENT WITHIN THE RECOMMENDED RANGE.
 2. THE U-MAD TRAILER TMA PROVIDES FOR MODERATE ADJUSTMENT TO ALIGN AND LEVEL THE TRAILER WITH THE TRUCK.
 3. VEHICLES CONFIGURED FOR USE WITH THE U-MAD TRAILER TMA SHALL HAVE SUPPORTED AREAS FOR INTERACTION WITH THE TRAILER'S ANTI-ROTATION SYSTEM UPON IMPACT. THE SYSTEM TYPICALLY INTERACTS WITH THE STANDARD UNDER-RIDE AND HITCH SYSTEM OF THE VEHICLE.
 4. VEHICLES WITHOUT THE STANDARD OR ADEQUATE UNDER-RIDE SHALL REQUIRE THE SUPPORT AREAS TO BE FABRICATED IN ADDITION TO THE PINTLE HOOK ASSEMBLY WITH A MINIMUM OF 6 TON CAPACITY.
 5. THE DETAILS BELOW ILLUSTRATE THE REQUIRED SUPPORT LOCATIONS AND A TYPICAL WELDED SUPPORT STRUCTURE.

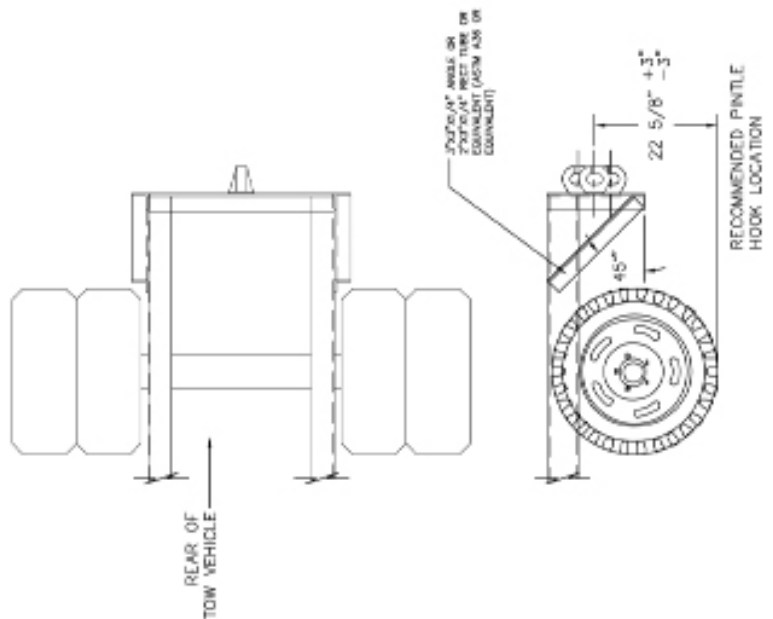

| | | | | | |
|---|---------|-------------|---|--|--|
| © 2006 Barrier Systems, Inc. No reproduction, storage, or distribution is permitted without the express written approval of Barrier Systems, Inc. | | SCALE: 1:20 | Standard Tolerance Angular ± 1/2° Fradial ± 1/16" ASME B1.12-2000 ASME B1.13-2000 | DATE: 07/25/08 DRAWN BY: JMB CHECKED BY: GDB | Barrier Systems Inc. 90 River St., 80 80th, CA 94017 Tel: 302-342-6800 Fax: 302-342-8360 |
| CHANGES | DATE BY | RECD | HEAT ASSEY | ITEM | REV. |
| | | | | | 0 |
| TITLE: U-MAD TRAILER TMA TRUCK INSTALLATION CONFIGURATION | | | | SHEET DRAWING NUMBER | 1 OF 1 B081258 |

Page Left Intentionally Blank



Lindsay Transportation Solutions Sales and Services, Inc

180 River Road • Rio Vista, CA 94571 • +1 707.374.6800 U.S. Toll Free: 888.800.3691 • www.barriersystemsinc.com

Installation manual details for the U-MAD Trailer System are subject to change without notice to reflect improvements and upgrades.

Additional information is available from Lindsay Transportation Solutions Sales and Service © Lindsay Transportation Solutions

UMADTRAILER 07022014 v11