

ARMORGUARD® GATE | LONGITUDINAL STEEL BARRIER GATE

- OPEN/CLOSE IN UNDER 2 MINUTES
- PERMANENT DEFLECTION 6" (160 mm)
- NCHRP 350 TL-3 ACCEPTED



PHYSICAL SPECIFICATIONS

Classification	Longitudinal Barrier Gate	
Length	26, 39, 52'	8, 12, 16 m
Width	28"	710 mm
Height	33"	840 mm
8 m Section-Weight	5527 lb.	2507 kg
Perm. Deflection	6"	160 mm

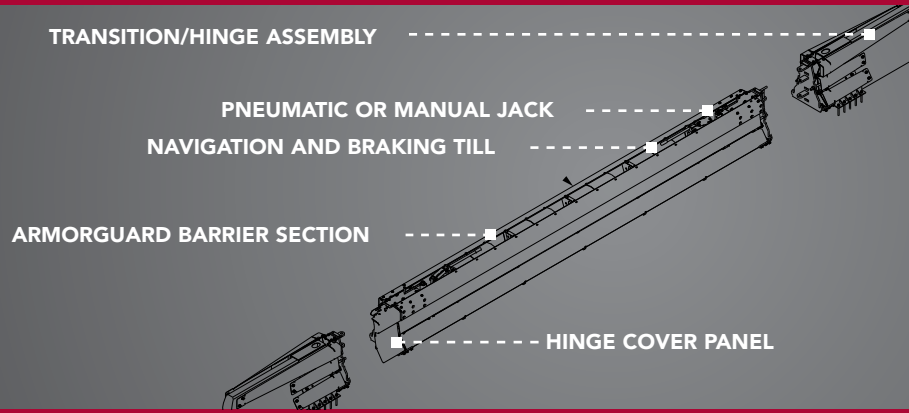

SAFELY SHIELDS MEDIAN OPENINGS

The ArmorGuard Steel Barrier Gate is a NCHRP 350 TL-3 longitudinal barrier gate designed for emergency openings, contraflow applications and workzone access. The ArmorGuard Gate system can be safely opened or closed in under 2 minutes using only manual power. Optional pneumatic jacks can be added to make opening the gate even faster. The System is easy to maneuver on steeper gradients with the use of a built-in navigation and braking till. The ArmorGuard Steel Barrier Gate has been performance tested on all road surface types, including gravel. The ArmorGuard Steel Barrier Gate is available in 26', 39' or 52' (8, 12 or 16 m) sections.

FREQUENTLY ASKED QUESTIONS

Are gates larger than 52' (16 m) available?

Yes, ArmorGuard Gate systems can be custom ordered in any size above 52'. System lengths above 52' (16 m) must be ordered in 26' (8 m) increments.

How long does it take to open or close the ArmorGuard Gate?

Less than two minutes are typically needed to open or close the ArmorGuard Gate.

Can the ArmorGuard Gate be repaired after a design impact?

Yes, since the ArmorGuard Gate has been engineered using modular components, repairing the ArmorGuard Gate can be accomplished with the use of ArmorGuard spare parts. Spare parts are available through your local distributor or through the Lindsay Transportation Solutions Customer Care Center.

FEATURES

- » 6" (160 mm) Permanent Deflection, 26' (8 m) System tested
- » Can be deployed on gradients up to 8%
- » Robust transition design
- » Easily installed on bridge decks and viaducts
- » Available as a 26', 39' or 52' (8, 12 or 16 m) System
- » Easily opens without electricity
- » Performance tested to open and close in under 2 minutes.
- » Pneumatic option available

DISTRIBUTED BY:



Lindsay Transportation Solutions Sales and Services, Inc.

180 River Road • Rio Vista, CA 94571 • +1 707.374.6800 U.S. Toll Free: 888.800.3691 • www.barrriersystemsinc.com

General details for the ArmorGuard Gate System are subject to change without notice to reflect improvements and upgrades.

Additional information is available from Lindsay Transportation Solutions Sales and Services, Inc. © Lindsay Transportation Solutions, Inc.

PT # AGG04-03252013